

Design & Style 2023  
University of Twente

azli

arid

# Content & Abstract

This is the portfolio designing a meaningful personal object that reflects my personality. The design process consists of 6 major phases:

- Intro
- Analysis
- Ideation
- Conceptualization
- Detailing
- Realization

After exploring personal values and characteristic, a set of possible designs came to my mind, however a cello holder seemed the best fit for this project. Mainly because I have been playing cello for 8 years and though this time, it has evolved to be more than just an instrument for me. It is a friend who I can express myself with when words do not suffice. I want to take care of my cello with the best way possible, hence designing a cell holder. I wanted the design to convey different feelings, so it has two different side views, while being fluid and dynamic as music. One side looks like someone bending over, like a trustworthy, calm and warm hug from a loved person. While the other side is rising up, like a hand of a serving person, holding the bow and offering service as cello is a tool for me to feel better.

# Persona

I am interested in Art. Leave me alone in a gallery, museum or exhibition for hours, I'll be having a blast!

I like taking walks in the city, without a specific destination, just wandering and looking around.

Watching people with their styles makes me wonder about their lives. The curiosity turns into creativity eventually.

I play piano and cello for years now. They have been there for me during my hardest times, when I wasn't even able to express myself in form of words.

Through the eyes of a stranger, I am an intimidating, strong, and independent woman, but there is more than meets the eye.

I am a chaotic beauty with a bright smile and warm hugs; been told! With all going on in my life, I can organise my life and make time for my loved one :)



# IKIGAI

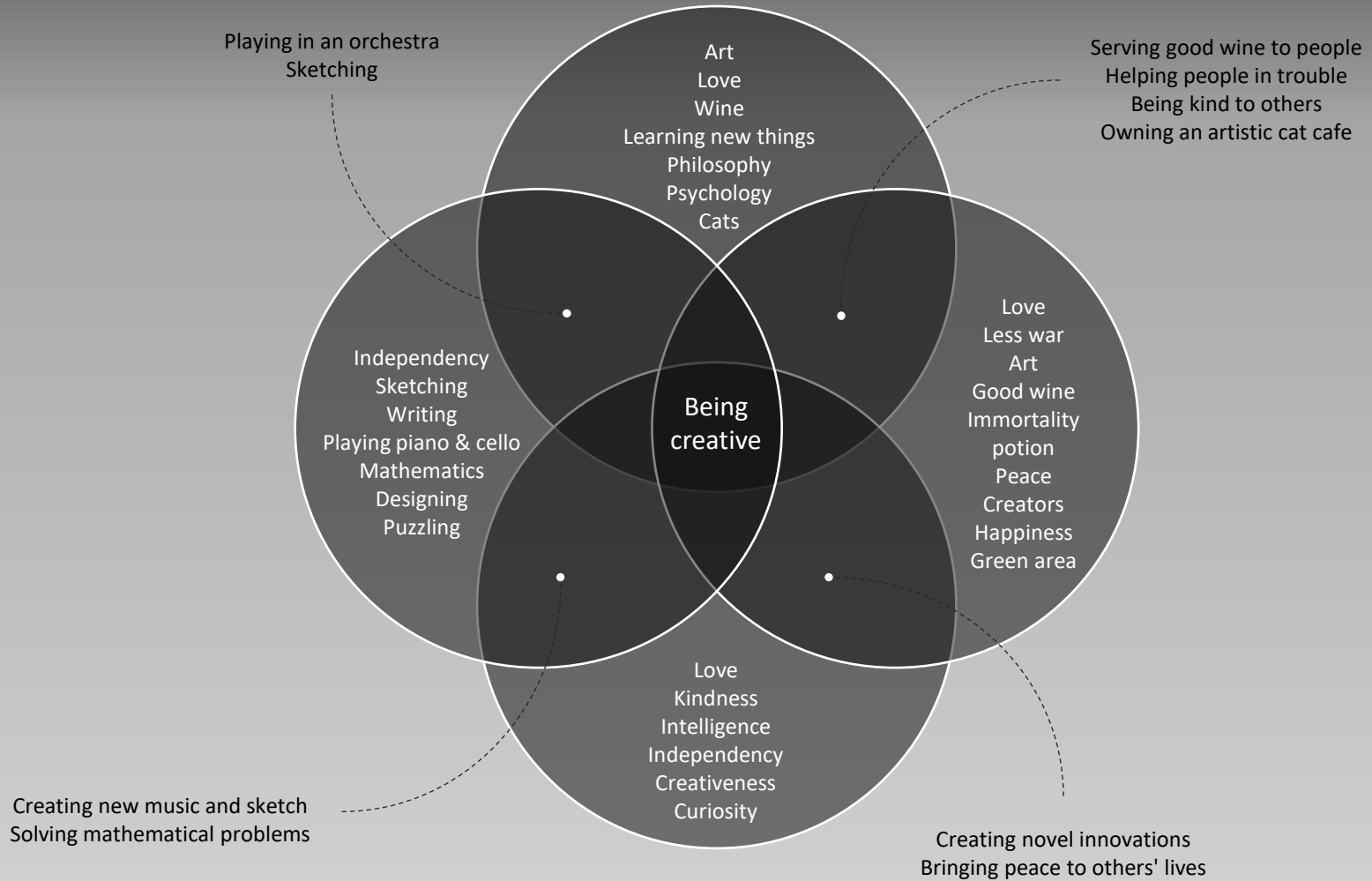

# Keywords about Me

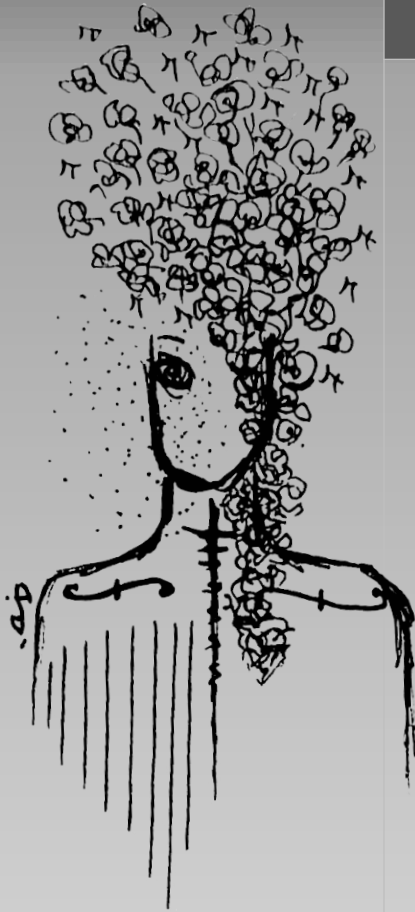

Chosen Qualities	Core Values
Independency	Integrity
Kindness	Autonomy
Creativity	Respect
Forgiveness	Bliss
Curiosity	Courage
Perspective	Generosity
Appreciation of Beauty & Excellence	Compassion
Social Intelligence	Influence
Zest	Boldness
Love	Intuition
Spirituality	Self-love
Love of learning	Harmony
Leadership	Balance
Gratitude	Accountability
Honesty	Promise-keeping
Fairness	Acceptance

# First Ideas for the Product

By taking a deeper look at the personal life, I came up with few alternative objects.

- An accessory piece, maybe a jewellery or a decoration token.
- An interesting instrument, with a strange way of functioning with a soothing yet outer-worldly sound
- a fountain pen
- A perfume bottle or a wine bottle, colourful with twisting shape
- A cello holder

I am the most enthusiastic about a cello holder. Cello has been my companion for years and it has become more than just a musician instrument for me. I want to design an object to take better care of my cello.

# Mood Board

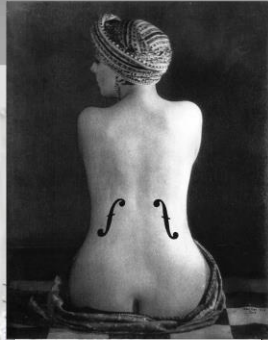

**Artsy**



**Aesthetic**



**Daring**



**Surreal**



**DADA**



Intro

Analysis

Ideation

Conceptualization

Detailing

Realization

# Style Collage

## Harmony



## Curvature



## Simple

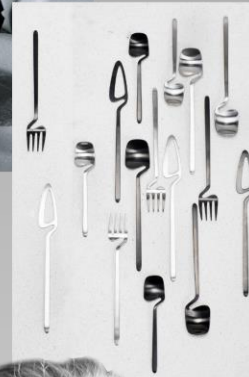
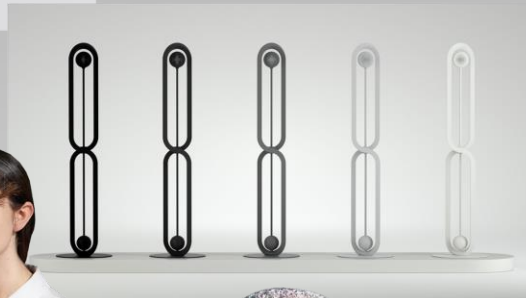

## Iconic



Intro

Analysis

Ideation

Conceptualization

Detailing

Realization

# Outcome of Collages

From mood board and style collage, I gathered that I am interested in surrealism, dadaism, modern art, and Avant-garde. I like the design to be artsy, evoking thought and conveying strong feelings.

Not everything in the collages have an over-complicated function, some are very simple and are designed solely for aesthetic purpose.

The form and shapes are mainly fluid and dynamic. Curvatures are unique, conveying sense of harmony as many lines follow same direction making a smooth wave of transition.

It can be concluded that design should be sculptural, perceptual and sensual. And as it is related to cello, it should fit the elegant and classic vibe of the cello as well.

Key words: Sculptural flexure, Harmony, Dynamic, Iconic, Sensual, Perceptual, Elegant, Classic

# The Design Vision

After researching my thought and feelings, with the help of the analysis phase, my design vision is articulated as...

An elegant and harmonious yet overwhelming design, containing details that reflects its purpose. It should convey different emotions and highlight the transition, evoking curiosity Eye-catching yet intangible, not fully comprehensible.

# Metaphors

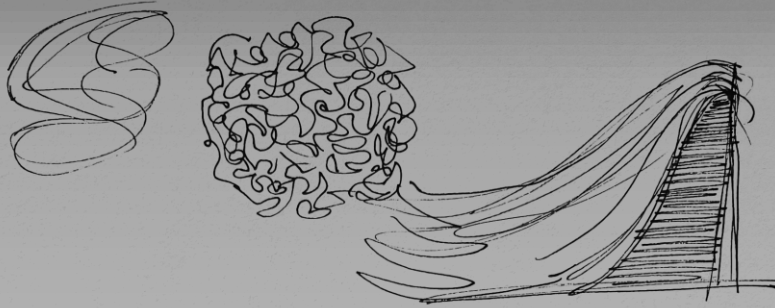

Some sketches are made according to the metaphors regarding my distinct personality. Main two metaphors are:

- Hurricane: Dark & Ever Changing
- Black Cat: Bold & Unpredictable

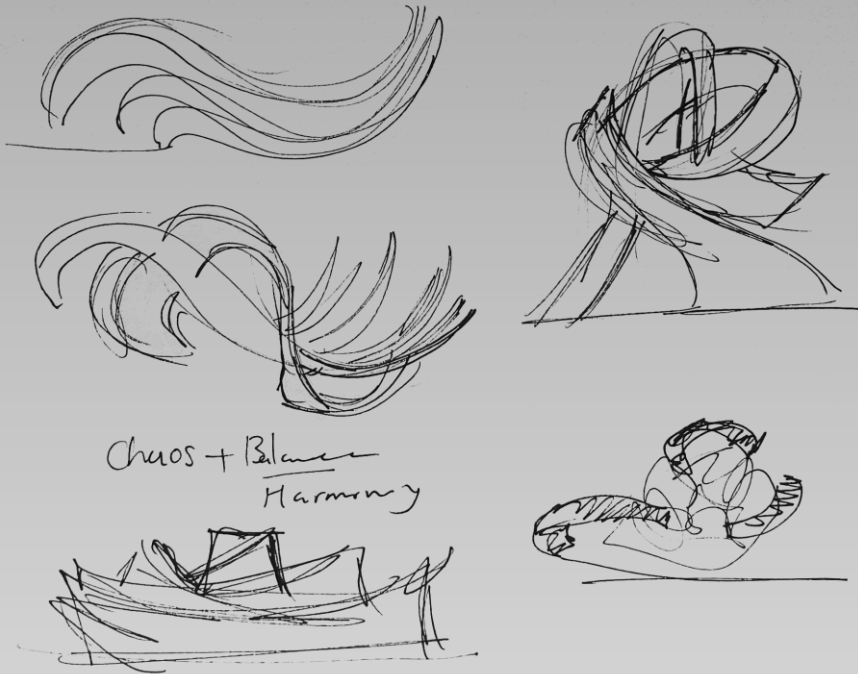

The cat clay sculpture was made during one of the workshops.



# Inspiration

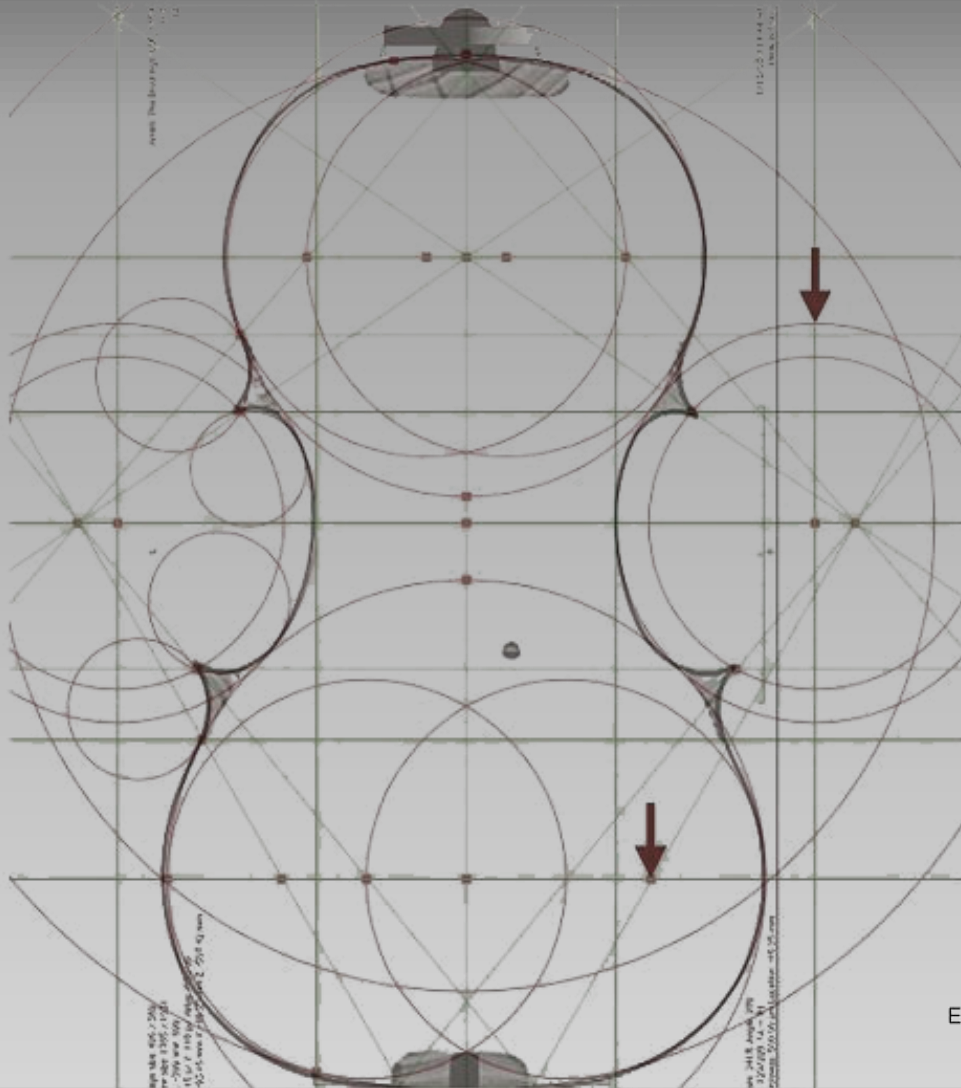

For inspiration, I mainly looked into musical figures, including articulation figures like clefs, notes, accessories.

Beside this, the shape of cello follows a geometric scheme, some parts use a logarithmic curves ending up in a spiral curve.

Modality is the key point of cello design.

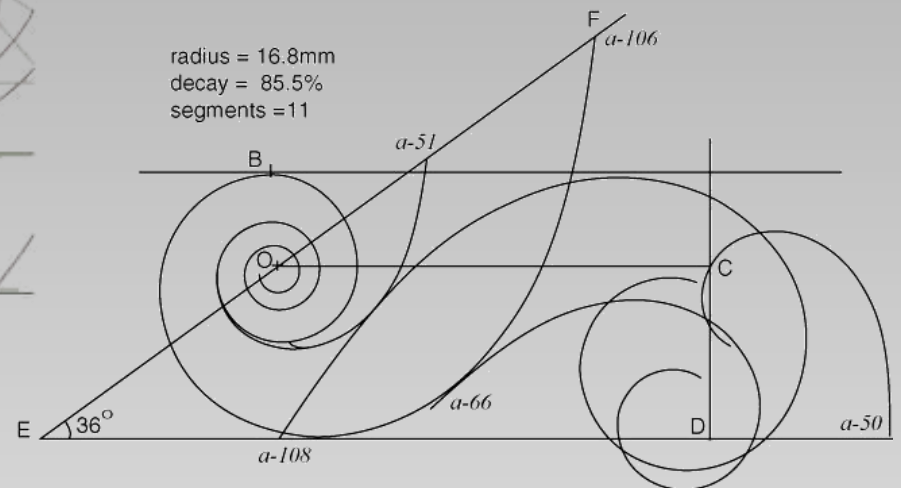

# Ideation

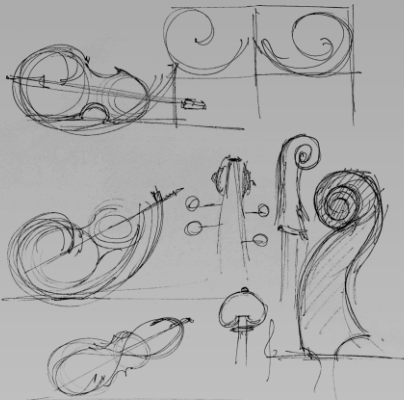
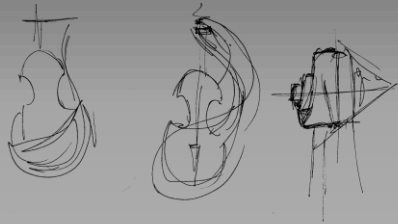

Main elements used in ideation are musical references, such as notes and clefs. These simple yet detailed figures follow many principles.

Sketches were made with using the inspiration while keeping the keywords derived from collages in mind. The outcome of the ideation, is three concepts.

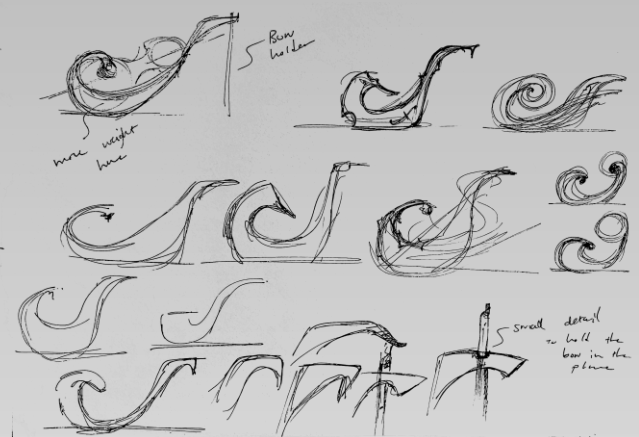
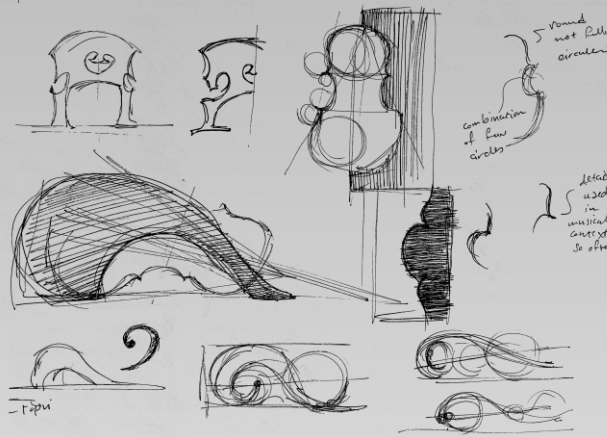
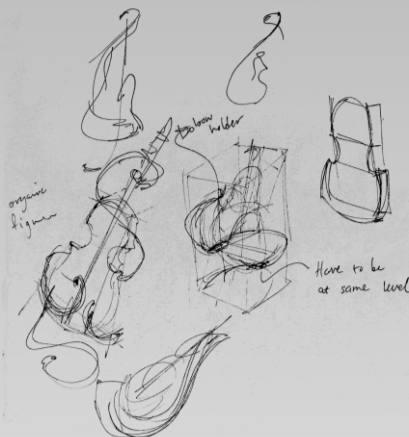

Intro

Analysis

Ideation

Conceptualization

Detailing

Realization

# Concept I

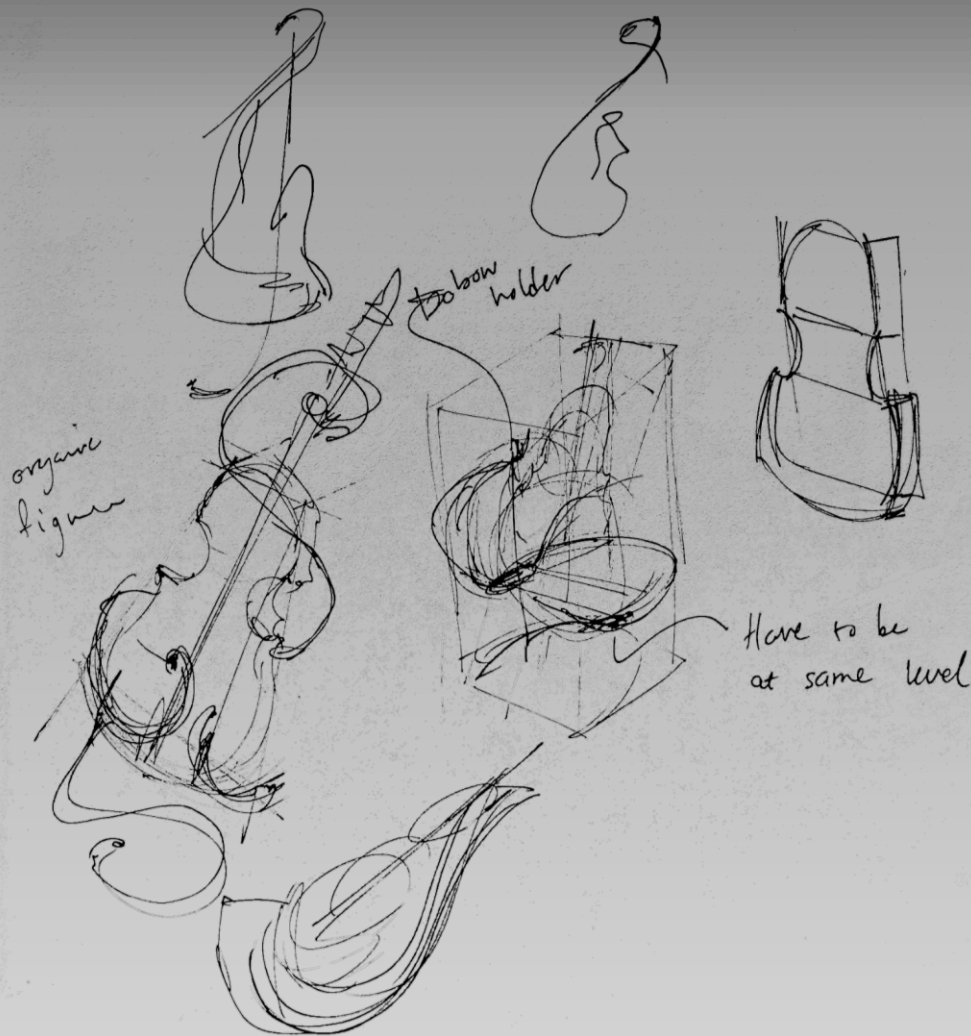

This concept, is a stand up holder. It looks light because of the cellular structure, nonetheless it is heavy and stable.

The main form is driven from the shape of the musical clefs, G and F. With their combination, the stand looks like it is embossing the cello.

The main advantage of this design, is the efficient use of the space.

# Concept II

The idea behind the shape is someone bending over, as an act of love and caring and embraces the cello. The shape is a spiral curve like a F-Clef. One side of the shape is bigger than the other, this is followed by the idea of the cello proportions and composition. This concept feels like a stable person to rely on.

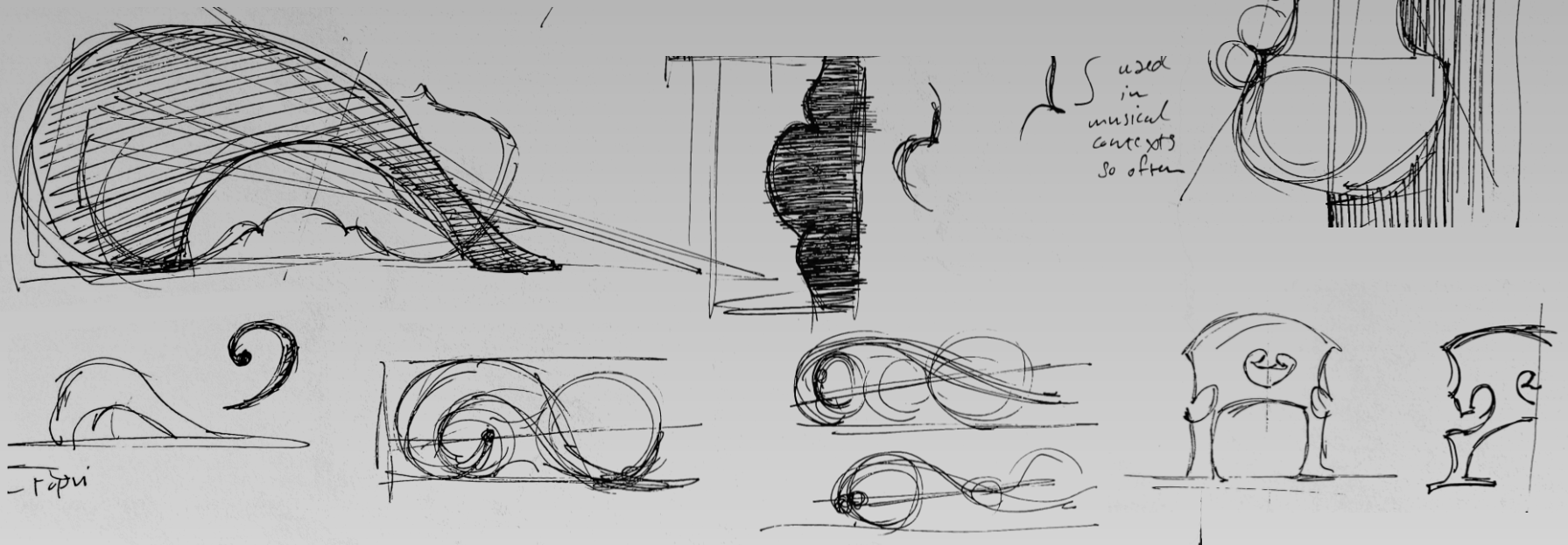

# Concept III

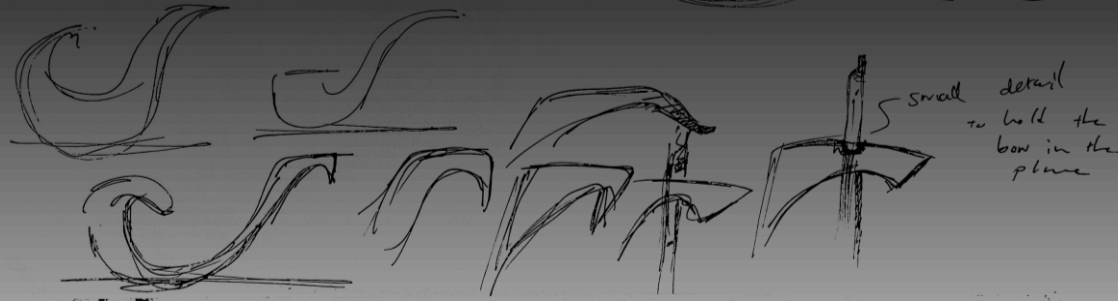

This shape almost conveys a contradicting feeling from concept II. It feels lighter and more dynamic. The idea behind the top part is hand of a butler, offering service which in this case would be holding the bow.

The spiral and curve shapes used in cello is implemented in main lines of the concept.

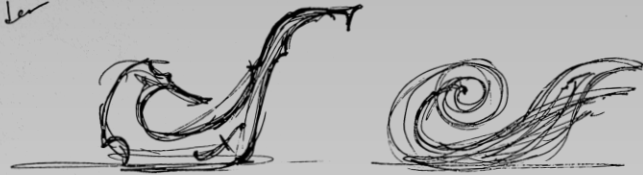
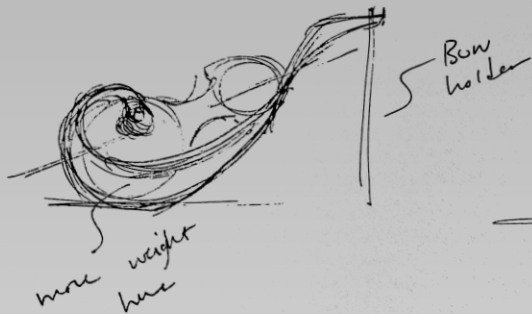
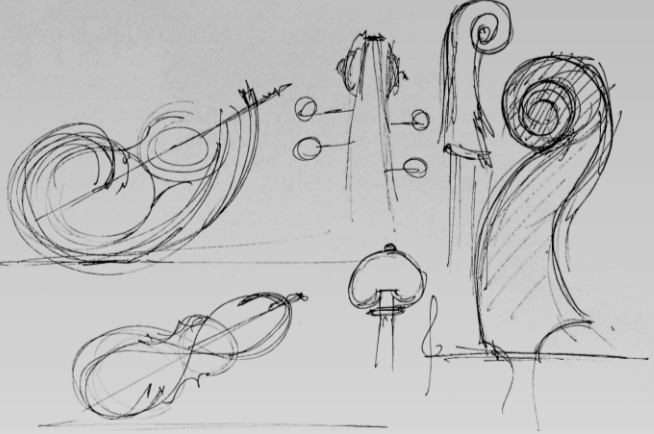
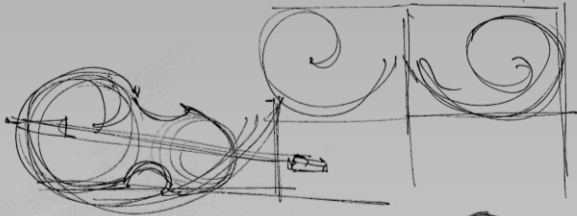
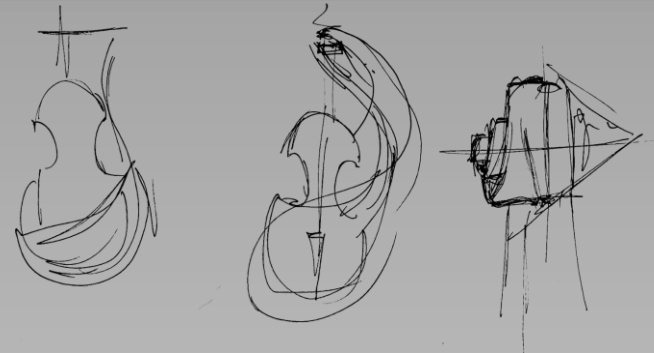

Intro

Analysis

Ideation

Conceptualization

Detailing

Realization

# Final Concept

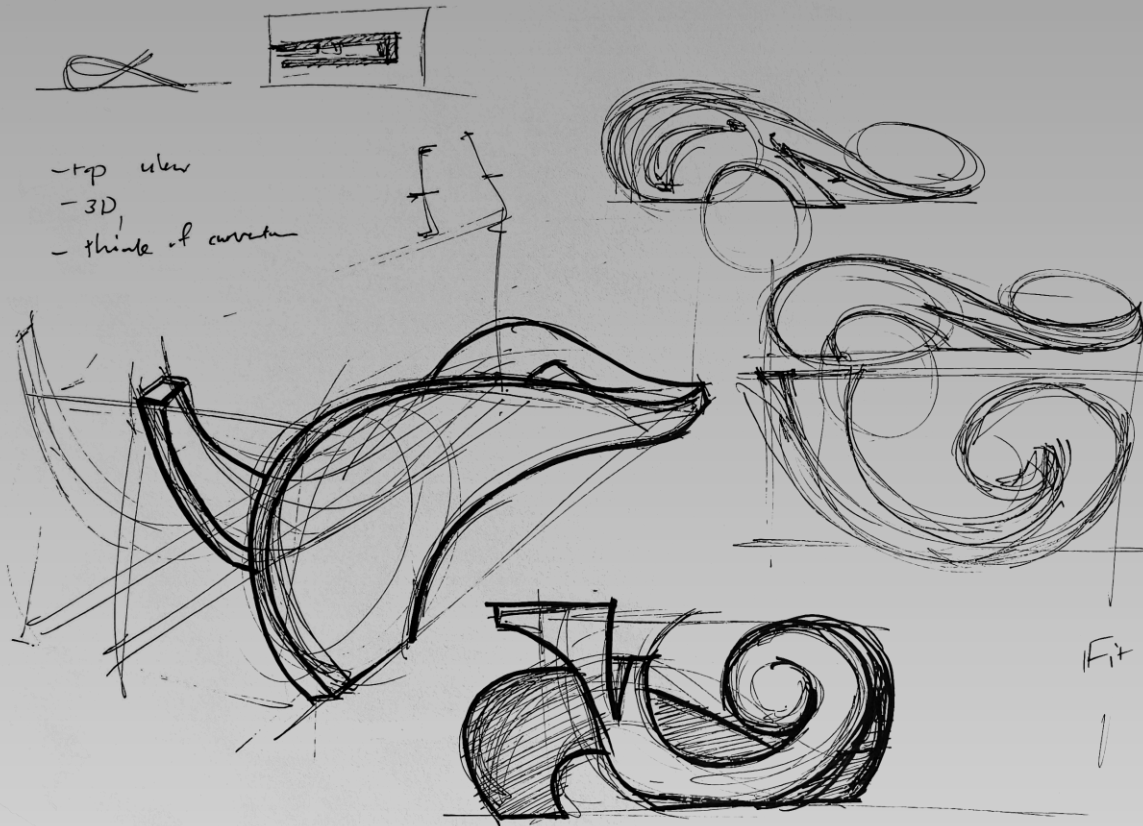

The final concept is a combination of concepts II and III. It has two different side views. One seems like a caring, loving person, other one being more open while still showing an act of service.

The general form, is harmonious and balanced. The cello can be placed in it with an angle, and the bow has a special spot as well.

# Final Concept

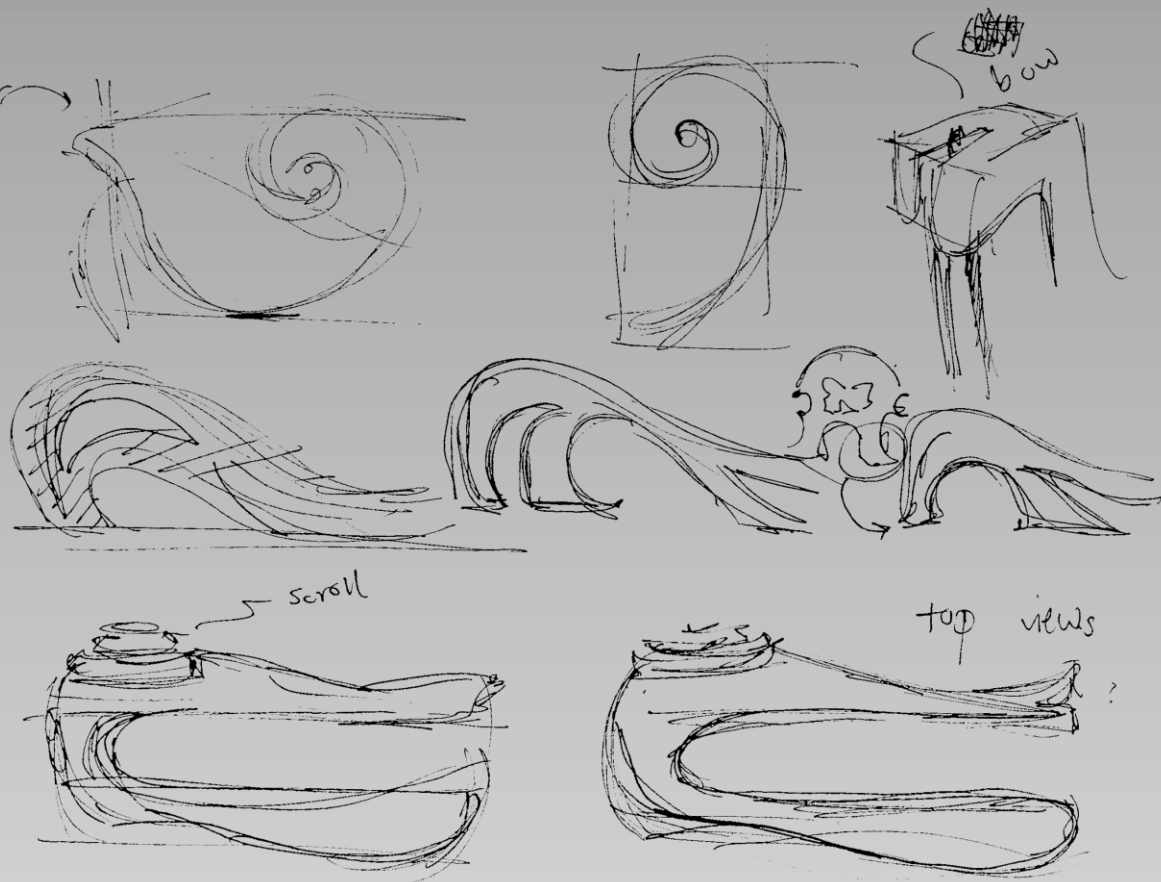

The lowered curvature is the side for placing the cello. In other side, there is a spot like a table, to put other object like music sheet on,

The design has two different materials, one is its outside which is darker colour, and the inside which is velvet based on the collages.

The shape also has an opening, because I wanted it to be more welcoming and convey an open and trusting sense to others, and making them see through the design more, would make it more transparent hence friendlier to others.

# Colour Collage



Intro

Analysis

Ideation

Conceptualization

Detailing

Realization

# Colour Analysis



As seen in the pallet, the main colours used in the collages are grey tones, either warm or cold. However, including a hint of an eye-catching colour, will emphasize on the difference of the materials as well, as in collages also a mild red colour was present.

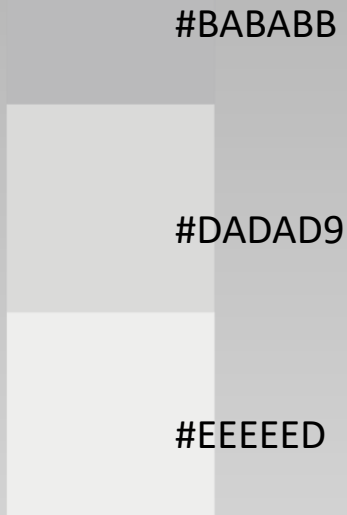
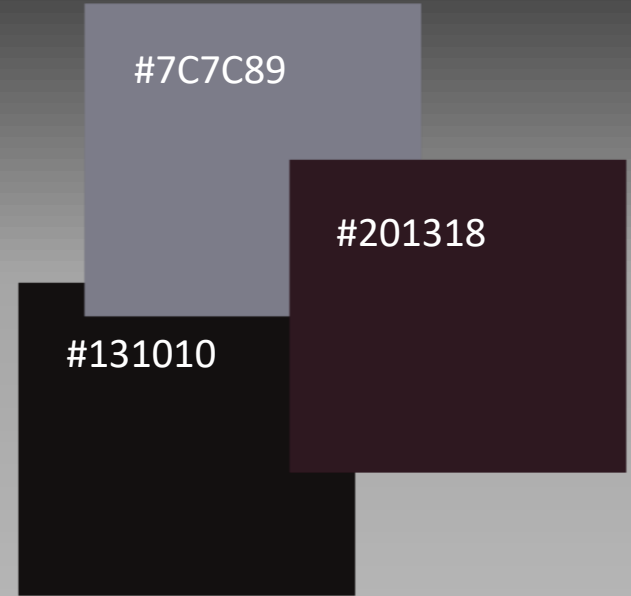

The inside of the hard cases for cello use velvet, usually classic and elegant colours such as Wine Red, Indigo Blue, And Phthalo Green.

# Detail Collage



Intro

Analysis

Ideation

Conceptualization

Detailing

Realization

# Detailed Concept

The main properties of the detailed concept includes:

- A void in the bending part
- A hook for a holding the bow
- Curvature like the scroll of cello
- A velvet fabric inside, with an elegant colour
- A small surface for putting other objects on it like music sheet
- The bending part enables to put cello in the holder easily
- The outside material is same with the hard case, carbon composite

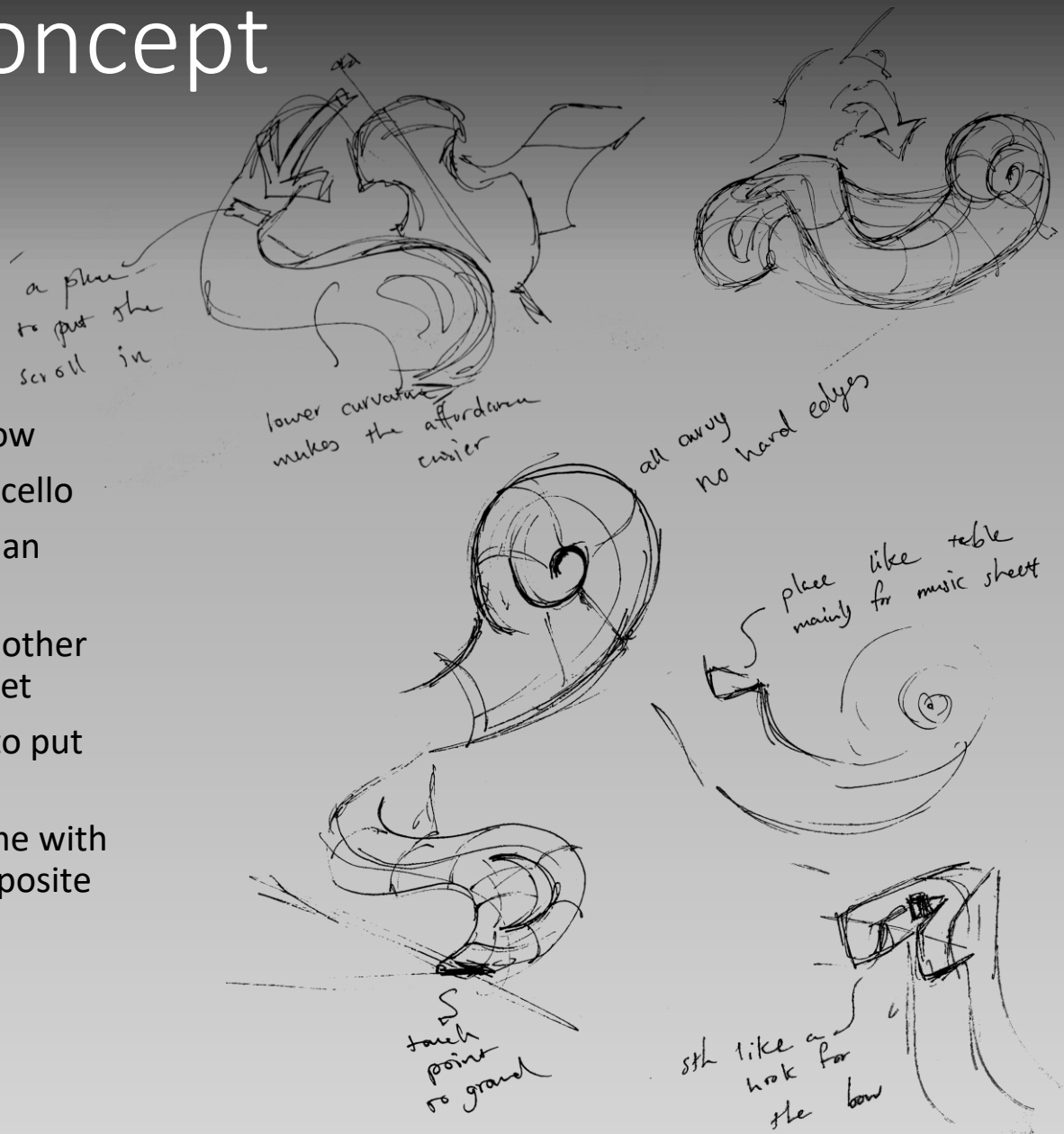

# Colour-Material-Finish

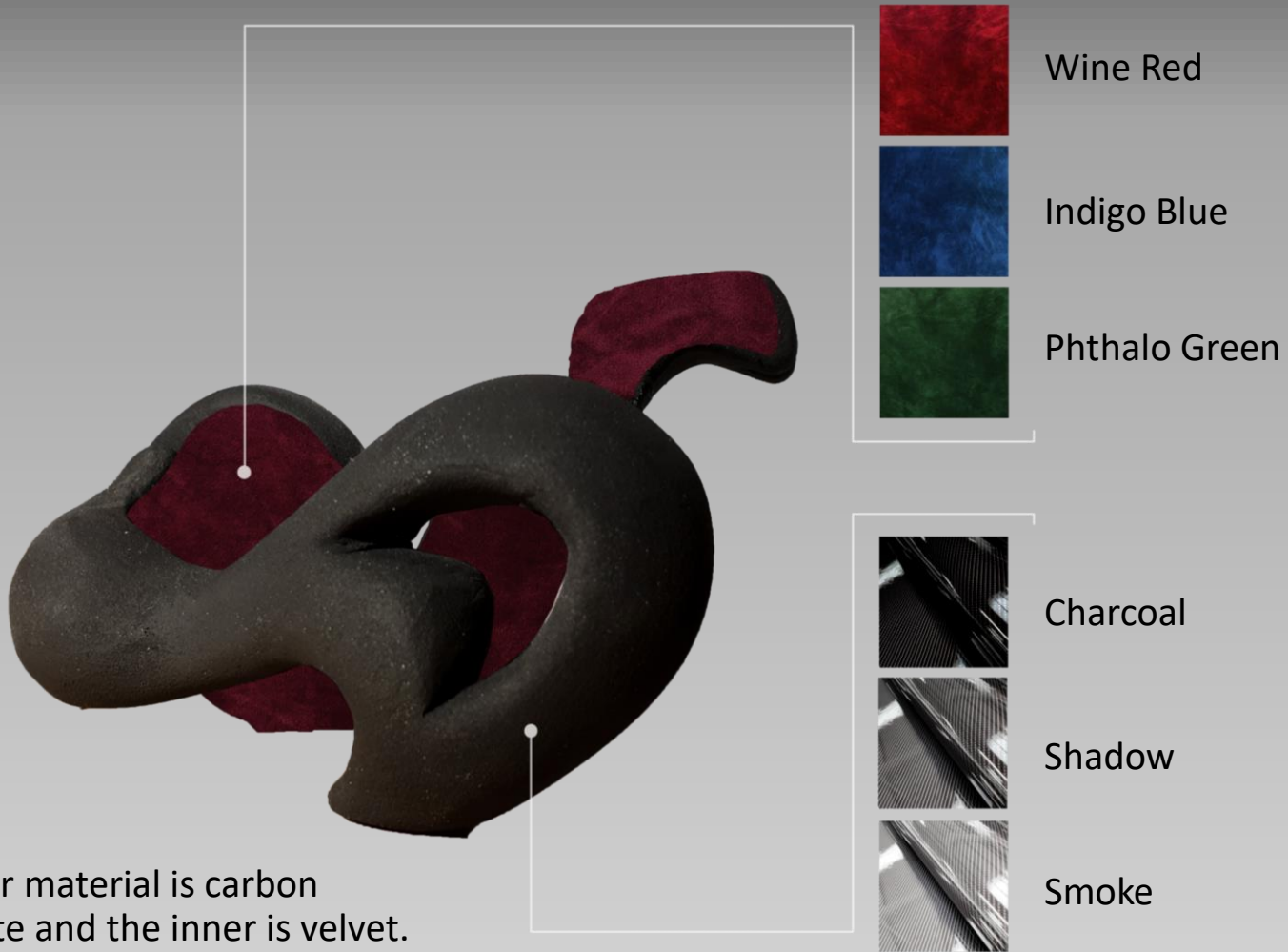

# Final Model



Intro

Analysis

Ideation

Conceptualization

Detailing

Realization